

## INSTALLATION INSTRUCTIONS | 2" Adjustable Downlight R2A Series

**Note:** Before attempting installation please refer to your local electrical code.

### INSULATED and NON-INSULATED CEILING APPLICATIONS

- The remodel version (R2ARM), all series, can NOT be installed in direct contact with insulation. Do not install insulation within 3" of fixture sides or wiring compartment, nor above fixture in such a manner to entrap heat.
- The new construction version (R2ANC), all series, can be installed in direct contact with insulation.

### REMODEL TYPE INSTALLATION PROCEDURES:

- Ensure you have the proper location for the housing. The flexible electrical cable above the ceiling needs to be in close proximity to the hole that will be drilled in the ceiling for easy access.
- The R2ARM module requires a precision fit with the ceiling opening. This opening needs to be a diameter of 3-1/4". It is highly recommended that a 3-1/4" hole saw be used for an accurate ceiling opening.
- Pull flexible cable through ceiling opening to wire fixture.
- Make all electrical connections (See "Electrical Connection").
- Insert remote junction box through ceiling opening, while maintaining low voltage harness and seismic tether accessible from below the ceiling opening.
- When used in fiberboard type tiles in grid ceilings, it is recommended to install the metal support ring provided to the back of the tile for added stability.
- Plug in low voltage harness from the remote junction box and connect the seismic tether to the corresponding connections on the Universal Module.
- Squeeze friction mounting springs on Universal Module to guide it through ceiling opening. Once the module is into ceiling opening, firmly push on the module's base ring to ensure springs engage and it sits flush against the ceiling.
- **NOTE:** Markings on Universal Module indicate direction of adjustability, careful consideration of orientation during installation will aid in aiming. (Figure 1).
- Module tilt adjustment can be performed using a finger or with the convenience slot for a flat blade screwdriver. (Figure 1).
- Tilt adjustment on Universal Module can be locked into place utilizing set screw and provided allen wrench. (Figure 2).
- See Trim Installation.

### NEW CONSTRUCTION TYPE INSTALLATION PROCEDURES

- Ensure you have the proper location for the housing. The flexible electrical cable above the ceiling needs to be in close proximity to the hole that will be drilled in the ceiling for easy access.
- The R2ARM module requires a precision fit with the ceiling opening. This opening needs to be a diameter of 3-1/4". It is highly recommended that a 3-1/4" hole saw be used for an accurate ceiling opening.
- Pull flexible cable through ceiling opening to wire fixture.
- Make all electrical connections (See "Electrical Connection").
- Insert remote junction box through ceiling opening, while maintaining low voltage harness and seismic tether accessible from below the ceiling opening.
- When used in fiberboard type tiles in grid ceilings, it is recommended to install the metal support ring provided to the back of the tile for added stability.
- Plug in low voltage harness from the remote junction box and connect the seismic tether to the corresponding connections on the Universal Module.
- Squeeze friction mounting springs on Universal Module to guide it through ceiling opening. Once the module is into ceiling opening, firmly push on the module's base ring to ensure springs engage and it sits flush against the ceiling.
- **NOTE:** Markings on Universal Module indicate direction of adjustability, careful consideration of orientation during installation will aid in aiming. (Figure 1).
- Module tilt adjustment can be performed using a finger or with the convenience slot for a flat blade screwdriver. (Figure 1).
- Tilt adjustment on Universal Module can be locked into place utilizing set screw and provided allen wrench. (Figure 2).
- See Trim Installation.

### ELECTRICAL CONNECTION - REMODEL:

- Local electrical codes should be consulted to determine acceptable installation: conduit, Romex or flexible metal cable.
- Remove the two screws on the junction box cover to allow wiring (R2ARM)
- A convenience 2-in-1 duplex connector is provided if daisy-chaining housings is desired. The duplex connector must be installed in the knockout located opposite the pre-wired low voltage harness. (Figure 3).
- Follow Wiring Diagram 1 for electrical/dimming options 12D and 27D. Triac dimming is not available for 27D, 277V option. Follow Wiring Diagram 3 for electrical/dimming options 12D4 and 27D4. (Wiring Diagrams, Page 4)
- Ensure all wires are safely within junction box. Close junction box and reinstall screws.

### TRIM INSTALLATION:

- Trims are held securely in place with friction springs. Simply push reflector into housing until it sits firmly against the ceiling.

### HOUSING REMOVAL AND LED DRIVER REPLACEMENT:

- NOTE:** LED Driver should be replaced by a qualified electrician. Turn off power at fuse or circuit breaker box before replacing the LED Driver.
- Pull trim straight down out of housing.
  - With fingers against housing walls pull down carefully. When springs (3) become exposed, depress and hold tightly against housing as it is being removed from ceiling. This will prevent springs from damaging the ceiling material.
  - Remove driver cover. (Figure 3)
  - Disconnect LED driver from line voltage input wiring in J-Box. Open up the LED driver enclosure and disconnect the LED driver from the LED leads (leads are terminated by crimp connectors).
  - Reinstall factory approved LED driver by reversing above procedure.

### ELECTRICAL CONNECTION - NEW CONSTRUCTION:

- Local electrical codes should be consulted to determine acceptable installation: conduit, Romex or flexible metal cable.
- Remove the outer junction box cover which is retained by spring (R2ANC).
- Follow Wiring Diagram 1 for electrical/dimming options MVD, MVD6, and MVD8. Triac dimming is not available for MVD, 277V option. Follow Wiring Diagram 2 for electrical/dimming option 12D3. Follow Wiring Diagram 3 for electrical/dimming option MVD4. Follow Wiring Diagram 4 for electrical/dimming options MVD7 and MVD9. (Wiring Diagrams, Page 4)
- Close junction box cover after wiring. Ensure that all wires are safely within junction box before closing.

### TRIM INSTALLATION:

- Trims are held securely in place with friction springs. Simply push reflector into housing until it sits firmly against the ceiling.
- **NOTE:** Slant cut reflectors should be aligned with adjustability of Universal Module for best performance.

All specifications subject to change without notice. For ConTech's limited product warranty, go to [www.contechlighting.com](http://www.contechlighting.com). For a printed copy of the warranty, call 1-847-559-5500.

## INSTALLATION INSTRUCTIONS | 2" Adjustable Downlight R2A Series

**Note:** Before attempting installation please refer to your local electrical code.

### UNIVERSAL MODULE REMOVAL AND LED DRIVER REPLACEMENT - REMODEL:

**NOTE:** LED Driver should be replaced by a qualified electrician. Turn off power at fuse or circuit breaker box before replacing the LED Driver

- Pull trim straight down out of Universal Module.
- Pull down on Universal Module base ring to gain access to friction springs on housing and ease de-installation.
- Once friction springs are accessible, squeeze to collapse and remove the Universal Module from the ceiling.
- Carefully pull remote driver box through the ceiling opening.
- Remove driver cover. (Figure 3).
- Disconnect LED driver from line voltage input wiring in J-Box. Open up the LED driver enclosure and disconnect the LED driver from the LED leads (leads are terminated by crimp connectors).
- Reinstall factory approved LED driver by reversing above procedure.

### HOUSING REMOVAL AND LED DRIVER REPLACEMENT - NEW CONSTRUCTION, MVD:

**NOTE:** LED Driver should be replaced by a qualified electrician. Turn off power at fuse or circuit breaker box before replacing the LED Driver

**NOTE:** The following instructions are for below ceiling access of R2ANCxMVD housings, if above ceiling access is available refer to 12D3/MVD4/MVD6/MVD7/MVD8 instructions.

- Pull trim straight down out of housing.
- Pull down on Universal Module base ring to gain access to friction springs and ease de-installation.
- Once friction springs are accessible, squeeze to collapse and remove the Universal Module from the ceiling.
- Remove smaller driver box, clipped to inside of housing, and pull through ceiling opening. (Figure 4)
- Remove driver cover. (Figure 3)
- Disconnect LED driver from line voltage input wiring in J-Box. Open up the LED driver enclosure and disconnect the LED driver from the LED leads (leads are terminated by crimp connectors).
- Reinstall factory approved LED driver by reversing above procedure.

### HOUSING REMOVAL AND LED DRIVER REPLACEMENT - NEW CONSTRUCTION, 12D3/MVD4/MVD6/MVD7/MVD8:

**NOTE:** LED Driver should be replaced by a qualified electrician. Turn off power at fuse or circuit breaker box before replacing the LED Driver

**NOTE:** Drivers, 12D3/MVD4/MVD6/MVD7/MVD8 dimming options, require above ceiling access for service and driver replacement.

- Remove the top cover of the NC housing (4 screws).
- Remove two wingnuts on driver mount plate. (Figure 4)
- Disconnect LED driver from line voltage input wiring in J-Box and disconnect the LED driver from the LED leads (leads are terminated by crimp connectors).
- Remove driver from driver mount plate and note orientation. (Figure 4)
- Reinstall factory approved LED driver by reversing above procedure.

### IMPORTANT SAFETY INSTRUCTIONS:

- Read all the instructions before installation. Save instructions for later use.
- Turn off power at fuse or circuit breaker box before installation or before doing any maintenance work.
- Product must be grounded to avoid potential electric shock and any other potential hazards.
- Product must be mounted in locations and at heights and in a manner consistent with its intended use, and in compliance with National Electrical Code and local codes. Use of accessory equipment is not recommended.
- Installing contrary to instructions may cause unsafe conditions.
- Do not block light from the trim aperture, in whole or in part, as this may cause unsafe conditions.
- **Warning:** Risk of fire. Most dwellings built before 1985 have supply wire rated at 60°C. Consult a qualified electrician before installation.
- Avoid hazards to children: account for all parts and properly dispose of all packing materials.
- Call the Technical Support department at ConTech Lighting with any installation questions: 847.559.5500.

### WARRANTY:

- Energy Star products are covered for three (3) years by a full replacement guarantee after date of installation. In addition, ConTech LED products carry a five (5) year limited warranty from date of purchase.

## INSTALLATION INSTRUCTIONS | 2" Adjustable Downlight R2A Series

**Note:** Before attempting installation please refer to your local electrical code.

### FIGURE 1

Markings on Universal Module indicate direction of adjustability, careful consideration of orientation during installation will aid in aiming. Module tilt adjustment can be performed using a finger or with the convenience slot for a flat blade screwdriver.

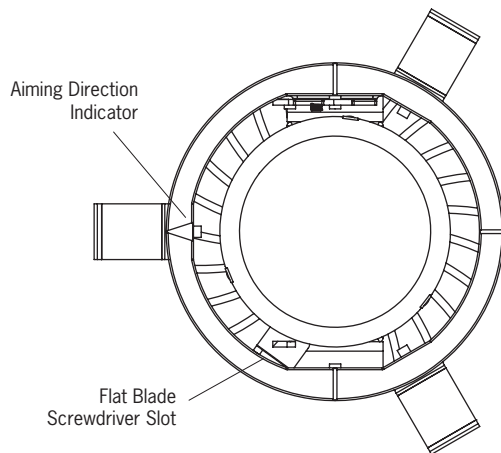

### FIGURE 2

Tilt adjustment on Universal Module can be locked into place utilizing set screw and provided allen wrench.

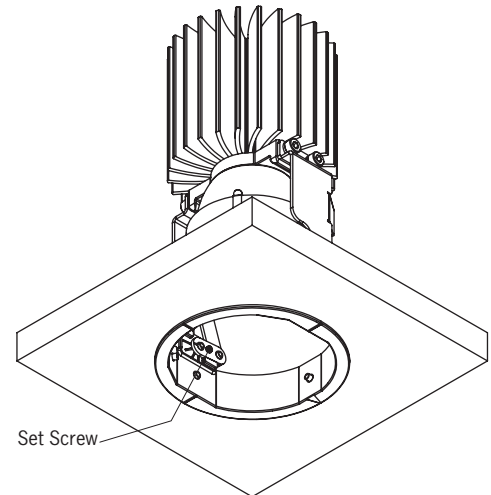

### FIGURE 3

A convenient 2-in-1 duplex connector is provided if daisy-chaining housings is desired. The duplex connector must be installed in the knockout located opposite the pre-wired low voltage harness.

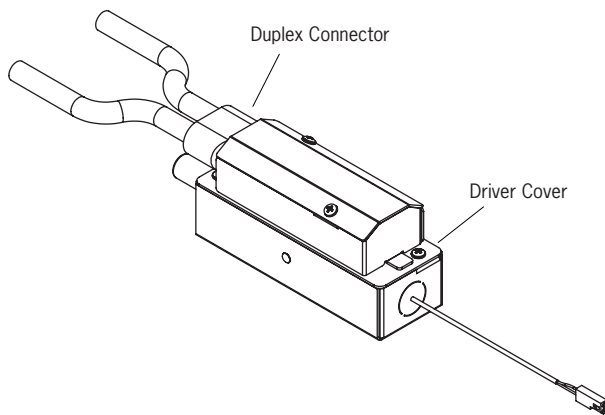

### FIGURE 4

Smaller driver box, clipped to inside of housing.

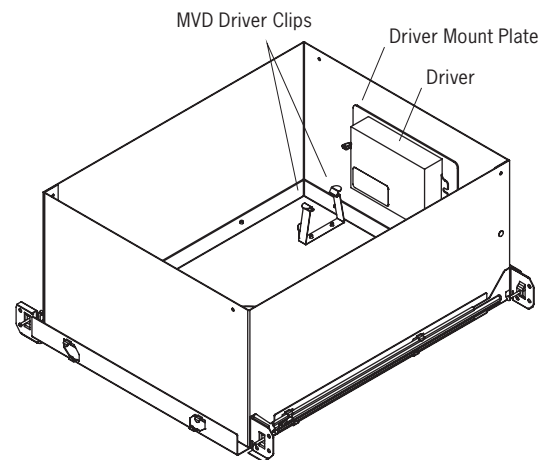

# INSTALLATION INSTRUCTIONS | 2" Adjustable Downlight R2A Series

**Note:** Before attempting installation please refer to your local electrical code.

## WIRING DIAGRAMS

### DIAGRAM 1

**MVD, 12D, 27D, MVD6, MVD8 Options**  
 120V or 277V Electrical/Dimming (Triac, ELV & 0-10V)  
*Triac and ELV Require Purple and Pink/Grey wires to be capped*

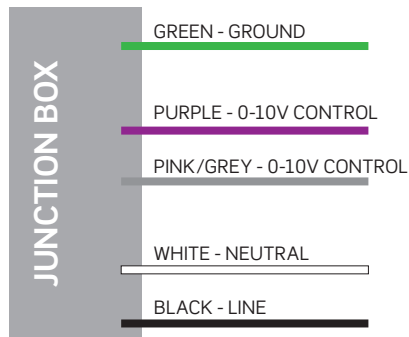

### DIAGRAM 2

**12D3 Option**  
 120V ONLY  
 120V Lutron HiLume Dimming

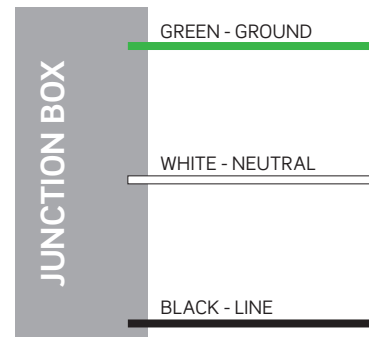

### DIAGRAM 3

**MVD4, 12D4, 27D4 Options**  
 120V or 277V  
 Lutron EcoSystem® Dimming

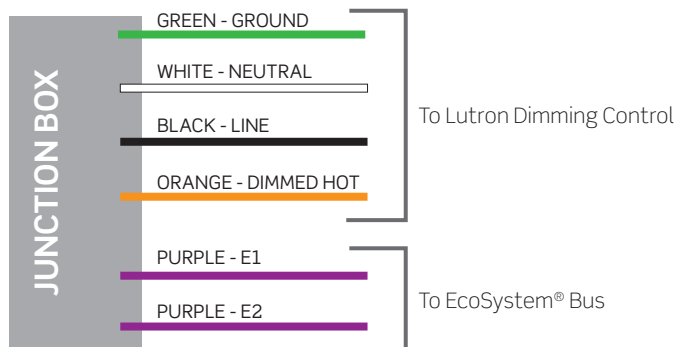

### DIAGRAM 4

**MVD7, MVD9 Options**  
 120V or 277V  
 Electrical/Dimming (DALI)

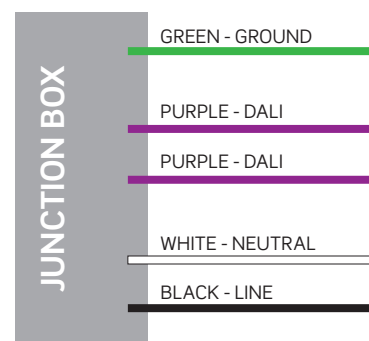

All specifications subject to change without notice. For ConTech's limited product warranty, go to [www.contechlighting.com](http://www.contechlighting.com). For a printed copy of the warranty, call 1-847-559-5500.