

INSTALLATION PROCEDURES

- **Housing can NOT be installed in direct contact with insulation.** Do not install insulation within 3" of fixture sides or wiring compartment, nor above fixture in such a manner to entrap heat. (Figure 1)
- Install hanger bars to fixture; ensure end tab is facing outward. (Figure 2)
- Extend bar hangers to fit between joists and position fixture by hammering nail on bars into the joists. Hangers should be level with bottom of the joists.
- Use T-Bar slot in the bottom bars for suspended (T-Bar) ceilings, bending the tabs to hold T-Bar tightly.
- Make all necessary electrical connections (See "Electrical Connection").

ELECTRICAL CONNECTION:

- Local electrical codes should be consulted to determine acceptable installation: conduit, Romex or flexible metal cable.
- Remove the junction box cover.
- Follow the proper wiring diagram for the electrical/dimming option (PAGE 2). Ensure wiring is the correct voltage for the fixture – either 120V or 277V.
 - **Wiring Diagram 1:** 12D, 27D, 12D6, 27D6, 12D8, 27D8 (Triac, ELV or 0-10V). Note: When dimming with 0-10V, Class 1 wiring (300V wiring inside conduit) is required. Please consult factory for additional details.
 - **Wiring Diagram 2:** 12D3 (Lutron HiLume)
 - **Wiring Diagram 3:** 12D4, 27D4 (Lutron EcoSystem)
 - **Wiring Diagram 4:** 12D7, 27D7, 12D9, 27D9 (DALI)
- Close junction box cover after wiring. Ensure all wires are safely within junction box before closing.

PULL DOWN TRIM/LED MODULE INSTALLATION:

- Attach harness from housing to harness from trim using quick-connect. (Figure 3)
- Trim features graduations to ensure consistent alignment from fixture to fixture. The constant tension mechanism will hold the trim securely in desired position. For unintended aiming, the trim can be locked in place with the supplied allen wrench. (Figure 4)
- Squeeze the torsion springs together on the trim and insert them into the torsion brackets inside the housing. The torsion springs will securely seat the trim against the ceiling.

REPLACEMENT OF LED DRIVER:

NOTE: LED Driver should be replaced by a qualified electrician. Turn off power at fuse or circuit breaker box before replacing the LED Driver.

- Pull the trim from the housing.
- Disconnect the electrical connection. (Figure 3)
- Remove the J-Box cover with LED Driver attached to it by loosening the two (2) Thumb Screws. (Figure 5)
- Disconnect LED Driver from line voltage input wiring in J-Box. Disconnect the LED Driver from the LED leads (leads are terminated by crimp connectors).
- Reinstall Factory Approved LED Driver by reversing above procedure.

IMPORTANT SAFETY INSTRUCTIONS:

- Read all the instructions before installation. Save instructions for later use.
- Turn off power at fuse or circuit breaker box before installation or before doing any maintenance work.
- Product must be grounded to avoid potential electric shock and any other potential hazards.
- Product must be mounted in locations and at heights and in a manner consistent with its intended use, and in compliance with National Electrical Code and local codes. Use of accessory equipment is not recommended.
- Installing contrary to instructions may cause unsafe conditions.
- Do not block light from the trim aperture, in whole or in part, as this may cause unsafe conditions.
- **Warning:** Risk of fire. Most dwellings built before 1985 have supply wire rated at 60°C. Consult a qualified electrician before installation.
- Avoid hazards to children: account for all parts and properly dispose of all packing materials.
- Call the Technical Support department at ConTech Lighting with any installation questions: 847.559.5500.

WARRANTY

Energy Star products are covered for three (3) years by a full replacement guarantee after date of installation. In addition, ConTech LED products carry a five (5) year limited warranty from date of purchase.

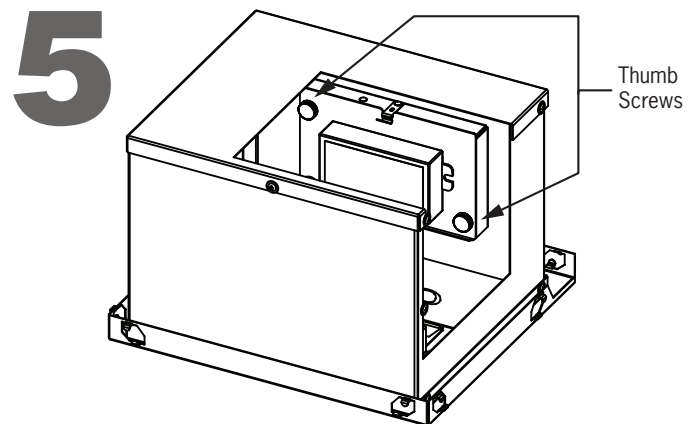
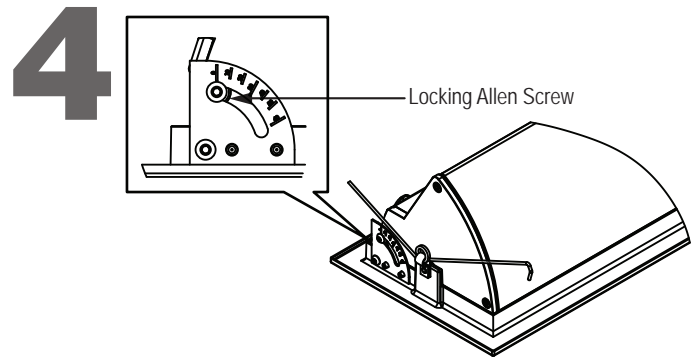
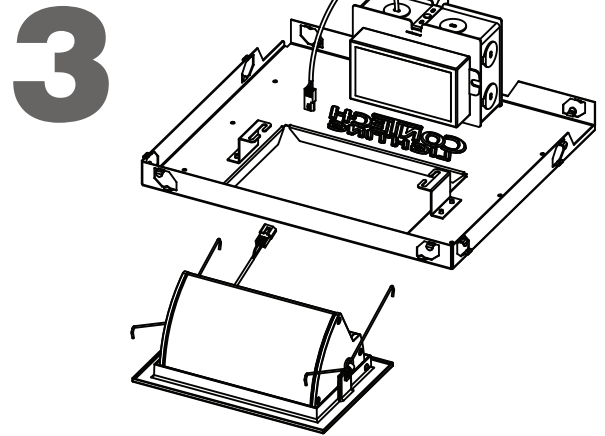
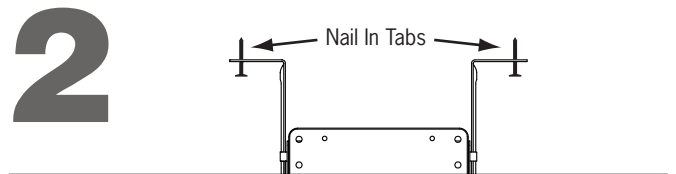
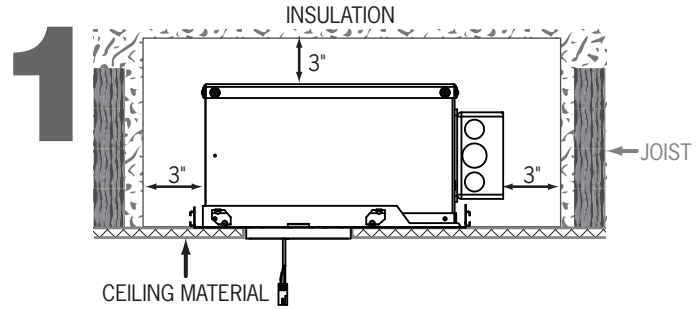

WIRING DIAGRAMS

WIRING DIAGRAM-1

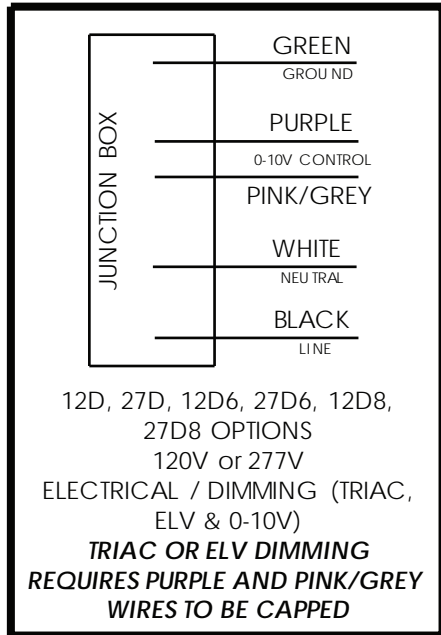

WIRING DIAGRAM-2

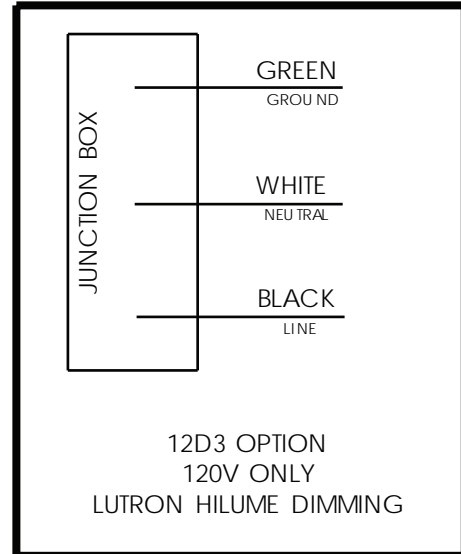

WIRING DIAGRAM-3

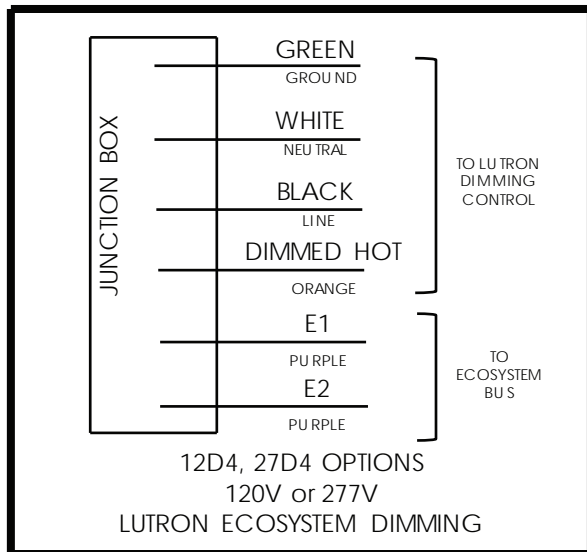

WIRING DIAGRAM-4

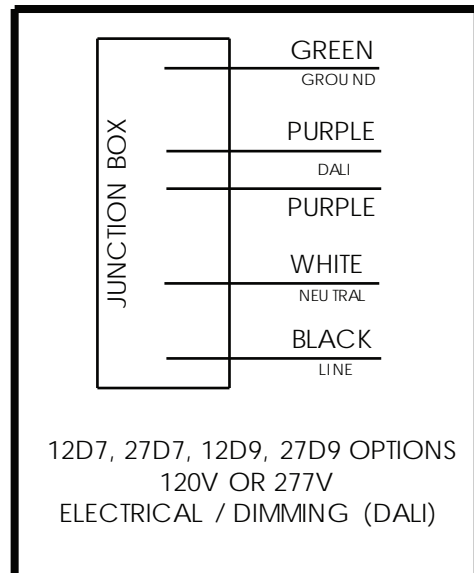

INSTALLATION INSTRUCTIONS

1. Insert LF49 lens, FA-54 louver, or FA-53 snoot into FA-19 accessory holder by placing edge of media under retaining clip as shown (FIG 1). Using two fingers on the bottom side of the accessory holder, depress opposite retaining clip inward and place lens in final position as shown (FIG 2). When inserting 2 pieces of media, install these stacked simultaneously.
2. Assemble FA-19 accessory holder to Stealth LED fixture by placing one side into position as shown (FIG 3) and pushing the other side of FA-19 into position until accessory holder retaining springs are securely engaged with the bezel.

IMPORTANT SAFETY INSTRUCTIONS:

- Read all the instructions before installation. Save instructions for later use.
- Before starting the installation, disconnect the power by turning off the circuit breaker or by removing the appropriate fuse at the fuse box. Turning the power off using the light switch is not sufficient to prevent electrical shock.
- Product must be grounded to avoid potential electric shock and any other potential hazards.
- Product must be mounted in locations and at heights and in a manner consistent with its intended use, and in compliance with National Electrical Code and local codes. Use of accessory equipment is not recommended.
- Installing contrary to instructions may cause unsafe conditions.
- Do not block light from the trim aperture, in whole or in part, as this may cause unsafe conditions. Do not mount near gas or electric heaters.
- Use caution when servicing batteries. Battery acid can cause burns to skin and eyes. If acid is spilled on skin or in eyes, flush with fresh water and contact a physician immediately.
- Equipment should be mounted in location and at heights where it will not readily be subject to tampering by unauthorized personnel.
- **Warning:** Risk of fire. Most dwellings built before 1985 have supply wire rated at 60°C. Supply conductors (power wires) connecting the fixture must be rated at minimum of 90°C. Consult a qualified electrician before installation.
- To avoid hazards to children, account for all parts and properly dispose of all packing materials.
- Call the Technical Support department at ConTech Lighting with any installation questions: 847.559.5500.

