

DECORATIVE SHADE INSTALLATION:

Open carton and remove the canopy driver compartment and set aside. Remove heatsink/leg assembly from carton and carefully set aside. Placing upright on four (4) legs to avoid scratching or damaging heatsink/leg assembly is recommended. Remove styrofoam packing insert from the bottom of the carton and place on table or work surface. Carefully place heatsink/leg assembly upside down on styrofoam packing insert to facilitate shade installation. (Figure 1) Place the aluminum, acrylic or glass shade within the four mounting legs. Position bottom ring in place and align four (4) holes. Thread and tighten four (4) 3mm hex socket head screws. (Figure 1)

BOTTOM GLASS INSTALLATION:

Thread four (4) knurled standoffs into the bottom ring. Unpack the bottom floating glass and attach (frosted side towards LED) to the bottom ring of the frame by aligning the four (4) holes with the four (4) knurled standoffs. Lock the glass in place with the (4) knurled cap nuts and carefully tighten. (Figure 1)

PERFORMANCE SHADE INSTALLATION:

Open carton and remove the canopy driver compartment and set aside. Remove heatsink assembly from carton and carefully set aside. Remove Styrofoam packing insert from the bottom of the carton and place on table or work surface. Carefully place heatsink assembly upside down on styrofoam packing insert to facilitate shade installation. Take the 16" acrylic, aluminum, or metal reflector shade and align the (3) holes on the shade to the (3) holes in the heatsink. Thread and tighten the shade with the (3) screws provided. **Performance shade will not fit into the Deco leg assembly. If legs are attached to the heatsink, please remove before installing the performance shades.**

IMPORTANT SAFETY INSTRUCTIONS:

- Read all the instructions before installation. Save instructions for later use.
- Turn off power at fuse or circuit breaker box before installation or before doing any maintenance work.
- Wear rubber soled shoes and work should be done on a sturdy wooden or non-conductive ladder.
- Product must be mounted in locations and at heights in a manner consistent with its intended use, and in compliance with National Electrical Code and local building codes. For indoor use only.
- Product must be grounded to avoid potential electric shock and any other potential hazards.
- Do not exceed the nominal supply voltage or amperage ratings.
- Make sure all screws are properly tightened.
- Do not install any lamp holder closer than 6" from any curtain or similar combustible material.
- Use only fixtures and fittings intended for use with ConTech Decorative Stemlight Pendant systems.
- Installing contrary to instructions may cause unsafe conditions.
- Warning: Risk of fire. Most dwellings built before 1985 have supply wire rated at 60°C. Consult a qualified electrician before installation.
- Warning: Risk of burns. Lamps are extremely hot when lit. Allow lamps to cool down in temperature before handling.
- To avoid hazards to children, account for all parts and properly dispose of all packing materials.
- Call the Technical Support department at ConTech Lighting with any installation questions: 847-559-5500.

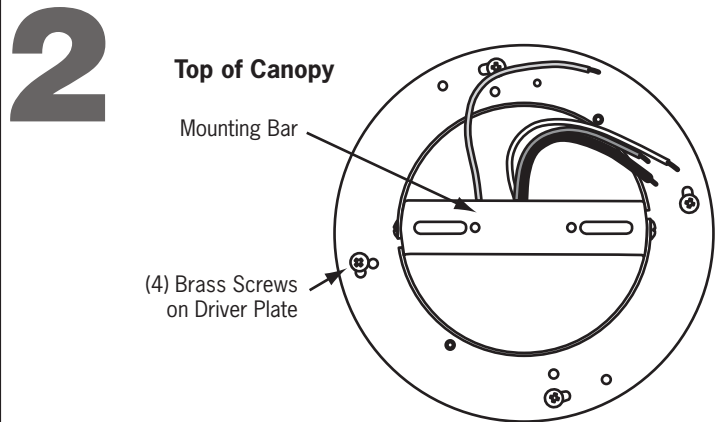
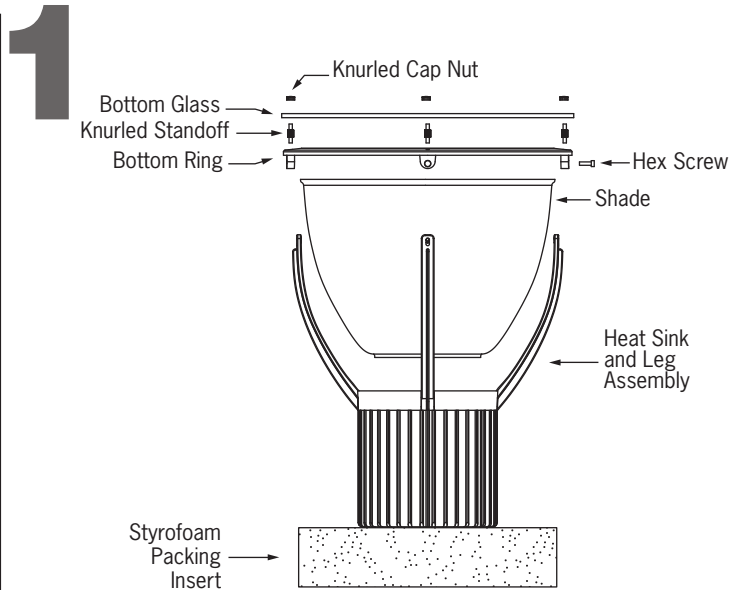

There should not be any excess cable in the ballast compartment. Leave only 6-8" for wiring available.

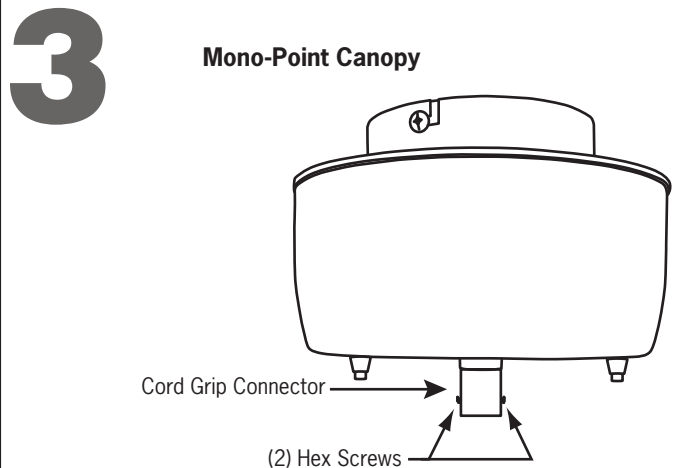

Continued on Page 2

FLEXIBLE CORD INSTALLATION:

To adjust the flexible cord length, remove the four (4) screws from the top of the canopy (Figure 2) and disconnect the red, black and green driver wires.

Determine the length of exposed flexible cord required. If cutting is required, loosen the coiled 18-3 cable. Leave only 6-8" for wiring available. Mark the cable where it needs to be cut. Carefully score the outer jacket around the diameter of the cable about 6-8" below the total length. Score the outer jacket lengthwise for that 6-8" section. Use proper rotary cable slitters such as Ideal #45-128 or Eclipse #200-009. Remove the outer jacket. Trim off the individual wire insulation leaving 1/2" bare wire exposed.

Install the internal two-piece cable strain relief. Tighten the two (2) 3mm hex socket head screws in order to hold the cord to the driver housing/canopy safely (Figure 3).

Reconnect the LED driver to the flexible cable. Connect red to black, black to white and green to green ground wires. (Figure 4) Once the flexible cable length is set, adjust the length of the aircraft cable to match by pulling the excess cable through the canopy. Once the length is properly adjusted, the excess cable can be coiled and left in the canopy or may be cut. Prior to cutting cable, the brass cable retainer must be repositioned. Loosen retaining screw with Philips head screwdriver, reposition the retainer approximately 1" - 2" from the canopy and retighten the retaining screw. Proceed with cutting of aircraft cable using proper aircraft cable cutting tools.

Reattach the top of the canopy with the four (4) screws. There should not be any excess flexible cord in the driver compartment/top mounting canopy. Per UL1598 and NEC 300.14, "at least 150mm (6in.) of free conductors and less than 8in., measure from the point in the box where it emerges from its raceway or cable sheath shall be left at each outlet, junction and switch point for splices or the connector of luminaires or devices".

RIGID STEM INSTALLATION:

For Rigid Stem installation, remove the four (4) screws from the top of the canopy (Figure 2) and disconnect the red, black and green driver output wires. The canopy with swivel is designed for sloped ceiling applications. Determine the length of the stem with external couplings required.

Loosen the two (2) 3.0mm steel hex socket head screws from the cable connector. Remove the inner grommet. Slide the stems over the flexible cord and screw the rigid stem into the cable connector and tighten the two (2) 3.0mm steel hex socket head screws. Determine the length of flexible cord required, and follow the flexible cord installation instructions for the balance of the installation.

CANOPY INSTALLATION:

Prior to installation, ensure a 4" Round or Square (with a Round-to-Square Junction Box Cover Plate) Junction Box is properly mounted to the ceiling structure.

Loosen the two (2) side screws on the canopy (Figure 4), unhook mounting chain and remove mounting bracket from the canopy. Attach the mounting bracket to junction box. Position canopy and pendant assembly close to mounting bracket and reconnect mounting chain.

ELECTRICAL CONNECTION:

Connect the primary leads from the junction box to the primary leads of the fixture (Black-to-Black, White-to-White and Green-to-Ground). (Figure 4)

Carefully tuck excess wires and connectors in Junction Box while positioning the canopy in place. Twist and lock canopy and tighten side screws to complete assembly.

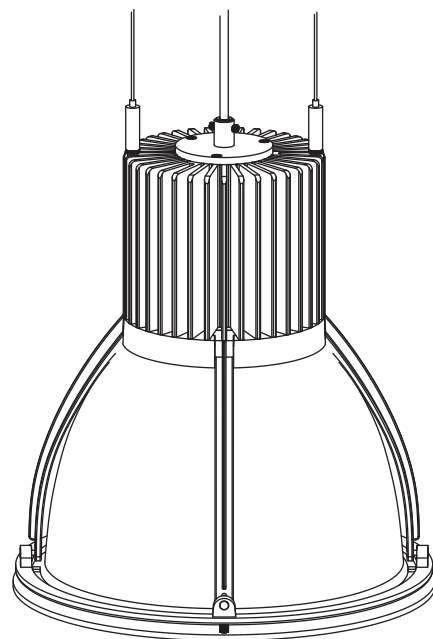
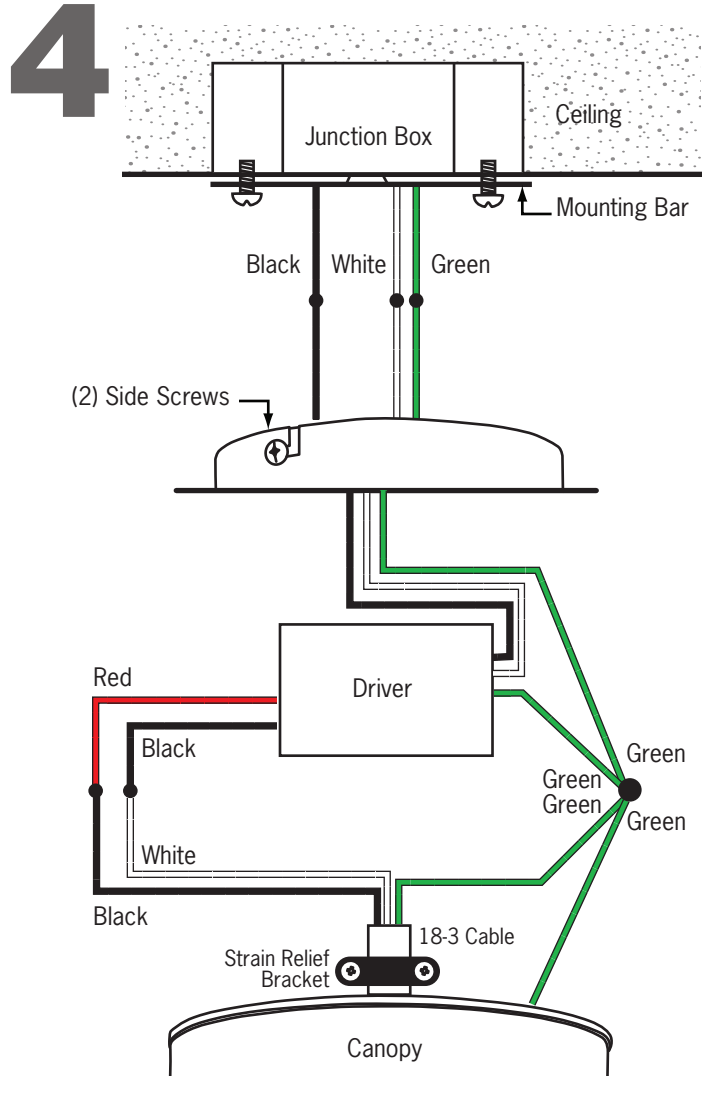

INSTRUCTIONS FOR CANOPY MOUNT EMERGENCY BATTERY BACK-UP

FLEXIBLE CORD INSTALLATION:

To adjust the flexible cord length, remove the four (4) screws from the top of the canopy (Figure 2) and disconnect the yellow battery back-up wire from the black 18-3 cable wire. Also disconnect the orange battery back-up wire from both the black driver wire and the white 18-3 cable wire. (Figure 4)

Determine the length of exposed flexible cord required. If cutting is required, loosen the coiled 18-3 cable. Leave only 6-8" for wiring available. Mark the cable where it needs to be cut. Carefully score the outer jacket around the diameter of the cable about 6-8" below the total length. Score the outer jacket lengthwise for that 6-8" section. Use proper rotary cable slitters such as Ideal #45-128 or Eclipse #200-009. Remove the outer jacket. Trim off the individual wire insulation leaving 1/2" bare wire exposed. Install the internal two-piece cable strain relief. Tighten the two (2) 3mm hex socket head screws in order to hold the cord to the driver housing/canopy safely (Figure 3).

Re-connect the yellow battery back-up wire to the black 18-3 cable wire. Also reconnect the orange battery backup wire to both the black driver wire and the white 18-3 cable wire. (Figure 4)

Once the flexible cable length is set, adjust the length of the aircraft cable to match by pulling the excess cable through the canopy. Once the length is properly adjusted, the excess cable can be coiled and left in the canopy or may be cut. Prior to cutting cable, the brass cable retainer must be repositioned. Loosen retaining screw with Philips head screwdriver, reposition the retainer approximately 1" - 2" from the canopy and retighten the retaining screw. Proceed with cutting of aircraft cable using proper aircraft cable cutting tools.

Reattach the top of the canopy with the four (4) screws. There should not be any excess flexible cord in the driver compartment/top mounting canopy. Per UL1598 and NEC 300.14, "at least 150mm (6in.) of free conductors and less than 8in., measure from the point in the box where it emerges from its raceway or cable sheath shall be left at each outlet, junction and switch point for splices or the connector of luminaires or devices".

RIGID STEM INSTALLATION:

For Rigid Stem installation, remove the four (4) screws from the top of the canopy (Figure 2). The canopy with swivel is designed for sloped ceiling applications. Determine the length of the stem with external couplings required.

Loosen the two (2) 3mm steel hex socket head screws from the cable connector. Remove the inner grommet. Slide the stems over the flexible cord and screw the rigid stem into the cable connector and tighten the two (2) 3mm steel hex socket head screws. Determine the length of flexible cord required, and follow the flexible cord installation instructions for the balance of the installation.

CANOPY INSTALLATION:

Prior to installation, ensure a 4" Round or Square (with a Round-to-Square Junction Box Cover Plate) Junction Box is properly mounted to the ceiling structure. Loosen the two (2) side screws on the canopy (Figure 4), unhook mounting chain and remove mounting bracket from the canopy. Attach the mounting bracket to junction box. Position canopy and pendant assembly close to mounting bracket and reconnect mounting chain.

ELECTRICAL CONNECTION:

Connect the primary leads from the junction box to the primary leads of the fixture (Black-to-Black, White-to-White and Green-to-Ground). Connect the un-switched hot lead from the junction box to the black wire marked "Un-Switched Hot" in the fixture canopy. (Figure 4)

Connect the crimped-on male-female connectors and carefully tuck excess wires and connectors in Junction Box while positioning the canopy in place. Twist and lock canopy and tighten side screws to complete assembly.

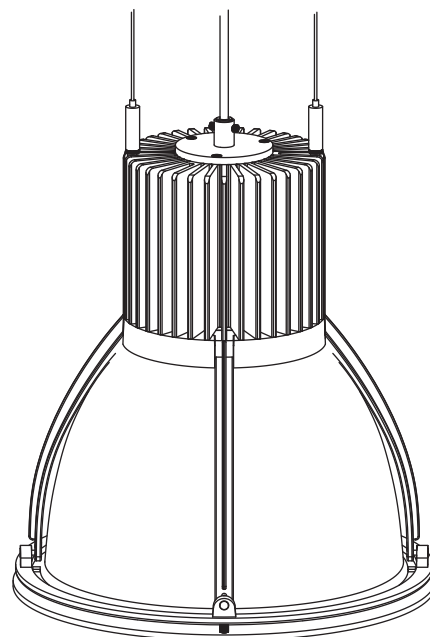
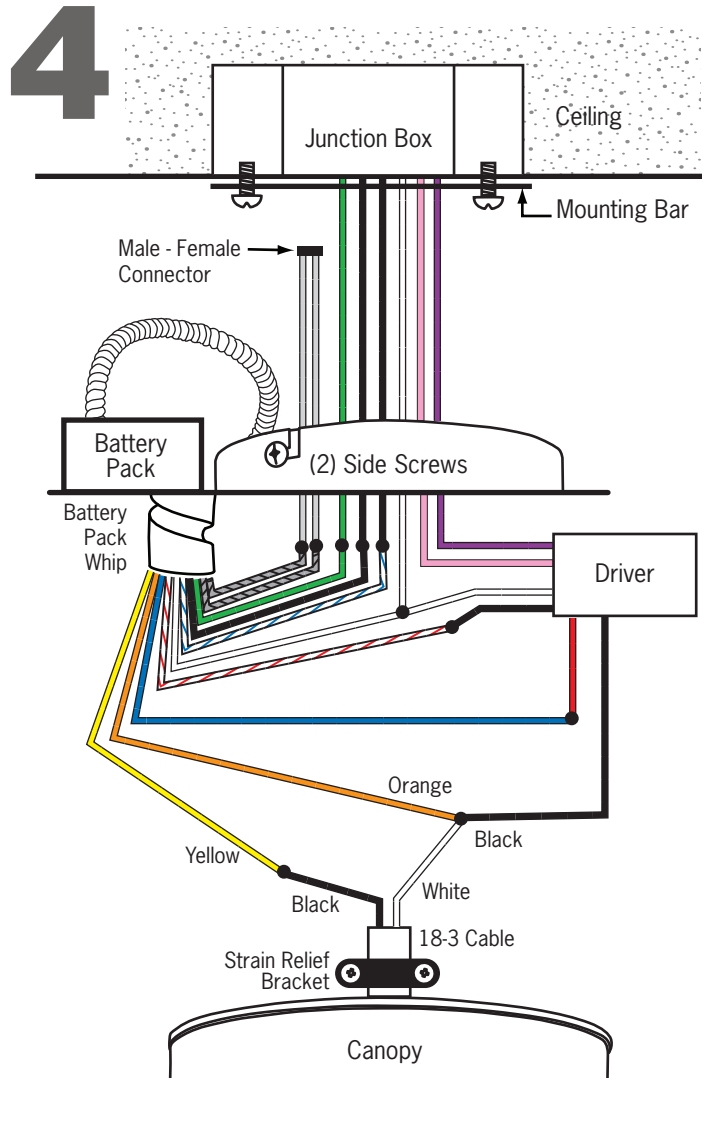

INSTRUCTIONS FOR REMOTE MOUNT EMERGENCY BATTERY BACK-UP

FLEXIBLE CORD INSTALLATION:

Determine the length of exposed flexible cord required. If cutting is required, loosen the coiled 18-3 cable. Leave only 6-8" for wiring available. Mark the cable where it needs to be cut. Carefully score the outer jacket around the diameter of the cable about 6-8" below the total length. Score the outer jacket lengthwise for that 6-8" section. Use proper rotary cable slitters such as Ideal #45-128 or Eclipse #200-009. Remove the outer jacket. Trim off the individual wire insulation leaving 1/2" bare wire exposed. Install the internal two-piece cable strain relief. Tighten the two (2) 3mm hex socket head screws in order to hold the cord to the driver housing/canopy safely (Figure 3). Once the flexible cable length is set, adjust the length of the aircraft cable to match by pulling the excess cable through the canopy. Once the length is properly adjusted, the excess cable can be coiled and left in the canopy or may be cut. Prior to cutting cable, the brass cable retainer must be repositioned. Loosen retaining screw with Philips head screwdriver, reposition the retainer approximately 1" – 2" from the canopy and retighten the retaining screw. Proceed with cutting of aircraft cable using proper aircraft cable cutting tools. There should not be any excess flexible cord in the driver compartment/top mounting canopy. Per UL1598 and NEC 300.14, "at least 150mm (6in.) of free conductors and less than 8in., measure from the point in the box where it emerges from its raceway or cable sheath shall be left at each outlet, junction and switch point for splices or the connector of luminaires or devices".

RIGID STEM INSTALLATION:

Determine the length of the stem required. The canopy with swivel is designed for sloped ceiling applications; external couplings must be considered when determining sloped ceiling stem length. Loosen the two (2) 3mm steel hex socket head screws from the cable connector. Remove the inner grommet. Slide the stems over the flexible cord and screw the rigid stem into the cable connector and tighten the two (2) 3mm steel hex socket head screws. Determine the length of flexible cord required, and follow the flexible cord installation instructions for the balance of the installation.

CANOPY INSTALLATION:

Prior to installation, ensure a 4" Round or Square (with a Round-to-Square Junction Box Cover Plate) Junction Box is properly mounted to the ceiling structure. To remove the junction box mounting bracket from the canopy, remove the two (2) screws from the face of the canopy. Attach junction box mounting plate to the junction box using two (2) screws. Carefully tuck excess wires and connectors in junction box while positioning the canopy in place. Re-attach canopy to junction box mounting plate using two (2) screws on the face of the canopy.

ELECTRICAL CONNECTION (FIGURE 5):

Mount the power supply per NEC requirements as well as local electrical code requirements. Run wire for the low voltage connection between the LED pendant and the power supply per NEC and local electrical code requirements. To hook up the power supply to the LED, remove the four (4) screws holding the cover plate on the driver box, connect the black wire from the LED cord to the black wire of the cord in the driver compartment. Connect the white wire from the LED cord to the white wire of the cord in the driver compartment. Replace the front cover by reinstalling the (4) screws. To connect power supply, remove the two (2) screws on cover of attached single-gang junction box, and connect black wire to junction box hot wire, white wire to junction box neutral wire, and green wire to ground. Connect the un-switched hot lead from the junction box to the black wire marked "Un-Switched Hot" in the fixture canopy. Replace junction box cover and two (2) screws. Lastly, after power is supplied to the fixture and power supply, connect white-black wires together using the crimped male-female connectors at the test switch connection. Test switch should be installed according to NEC and local code requirements.

4

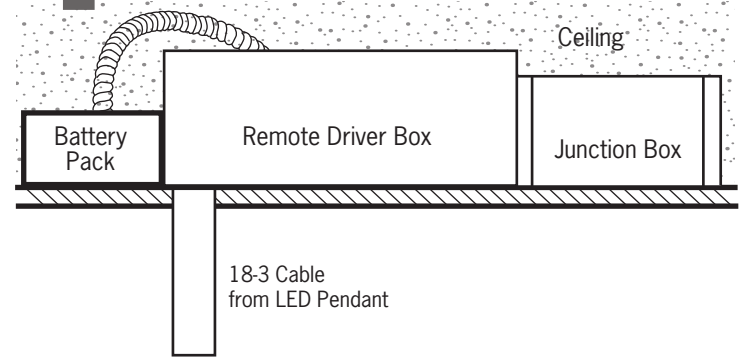

5

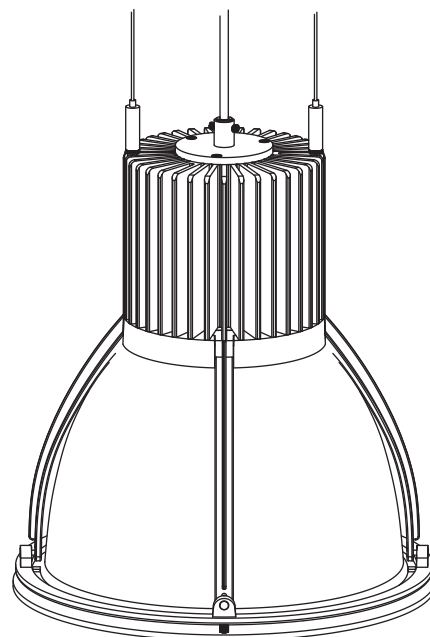
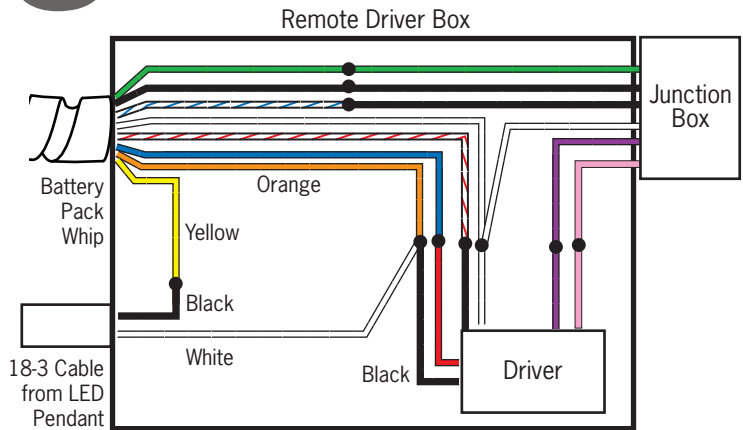

All specifications subject to change without notice. For ConTech's limited product warranty, go to www.contechlighting.com. For a printed copy of the warranty, call 1-847-559-5500.